

Hot Water Storage Tank

500 TO 10000++ LITRES
For larger tanks please contact factory

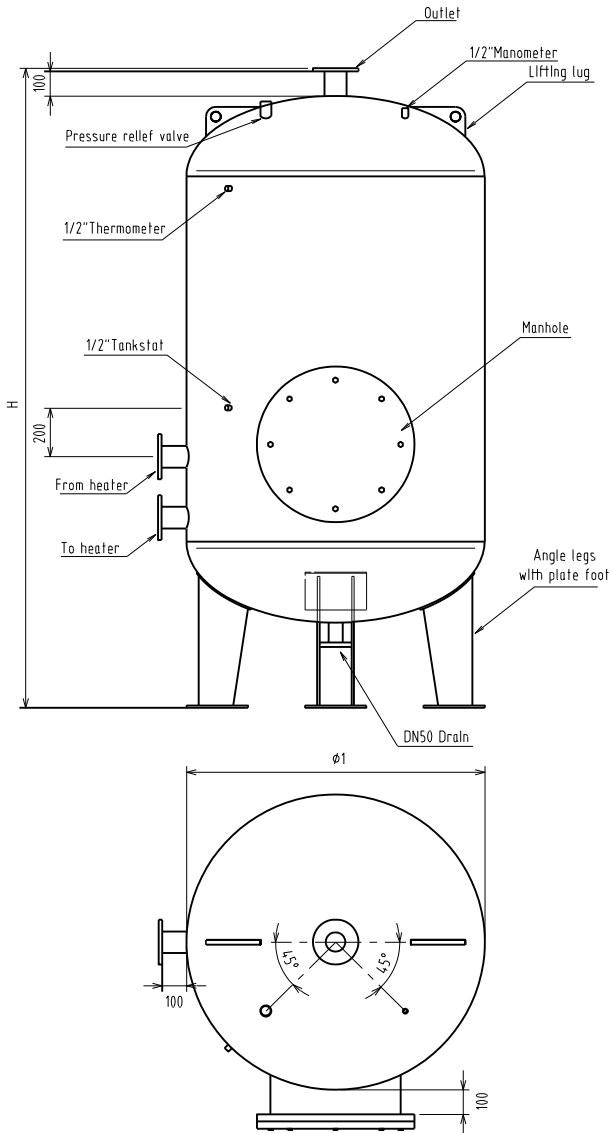

Vertical model

STANDARD FEATURES

- Tank material - SUS316L / SUS304 / SUS444
- Standard maximum working pressure - 0.6 MPa
- Flanged manhole
- Flanged / thread water connections
- Lifting lugs
- Angle legs (SUS304)
- Drain
- Pressure relief valve

Standard Max. Working Pressure - 0.6 MPa (Vertical Model)

Capacity (Litre)	Thickness (mm)	Dimension (mm)		Dry Weight (kg)
		H	Ø1	
500	5	2015	710	460
1000	6	1862	1000	460
2000	6	2362	1200	630
3000	6	3262	1200	790
4000	6	2662	1600	890
5000	6	3262	1600	1030
6000	8	3093	1800	1390
7000	8	3443	1800	1596
8000	8	3893	1800	1866
9000	8	4293	1800	2010
10000	8	4693	1800	2156

Note: The technical specification of the tank is not fixed. It is customizable according to customers' requirement.

OPTIONS

- Maximum working pressure - up to 4.0 MPa
- Horizontal model

NOMENCLATURE: (Please indicate clearly when placing order)

SGL-1600-5.0-0.6-304

Non-Vented Tank	Outer Diameter (mm)	Capacity (m ³)	Max. Working Pressure (MPa)	Material:
SGL: Vertical				304: SUS304
SGW: Horizontal				316: SUS316L
				444: SUS444

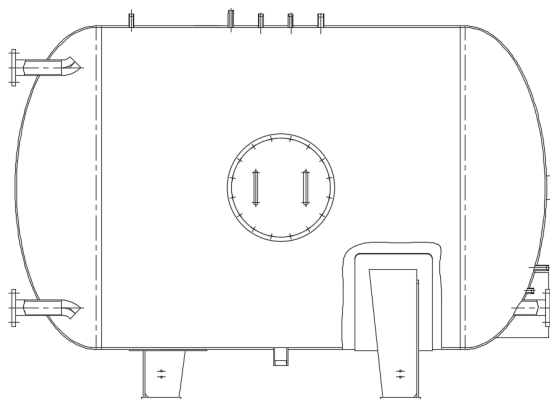

Horizontal model

